

Similarity Through Transformations

6



The first U.S. mass-produced marbles were made in Akron, Ohio in the early 1890's. But marbles have been around a lot longer than that. Some of the earliest records of marbles are from ancient Rome and Egypt!



6.1	Big and Small	
	Dilating Triangles to Create Similar Triangles	437
6.2	Similar Triangles or Not?	
	Similar Triangle Theorems.	451
6.3	Keep It in Proportion	
	Theorems About Proportionality.	463
6.4	Geometric Mean	
	More Similar Triangles	481
6.5	Proving the Pythagorean Theorem	
	Proving the Pythagorean Theorem and the Converse of the Pythagorean Theorem	489
6.6	Indirect Measurement	
	Application of Similar Triangles.	495

Big and Small

Dilating Triangles to Create Similar Triangles

LEARNING GOALS

In this lesson, you will:

- Prove that triangles are similar using geometric theorems.
- Prove that triangles are similar using transformations.

KEY TERM

- similar triangles

Making hand shadow puppets has a long history. This activity goes back to ancient China and India. Before the invention of television, or even radio, hand shadows were used to entertain people by telling stories.

Today, you can find tutorials online that will show you how to create really complicated and interesting shadow puppets. Groups of people can get together and create entire landscapes and scenes—all with the shadows made by their hands!

PROBLEM 1 A New Marbles Game?



The game of marbles is played in a circle. The goal is to knock your opponents marbles outside of the circle by flicking a shooter marble at the other marbles in the circle. The shooter marble is often larger than the other marbles.

John placed a shooter marble near three smaller marbles as shown.

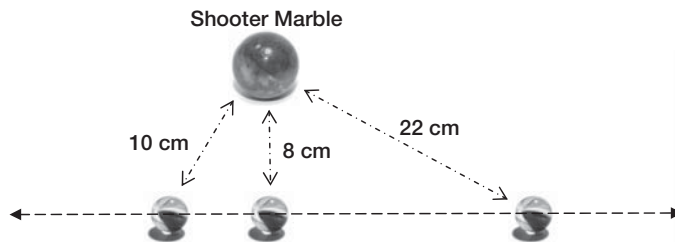

Can you describe the 3 smaller marbles as being collinear?



1. Draw another row of three marbles under the first row of marbles using a dilation factor of 2 with the shooter marble as the center of the dilation.

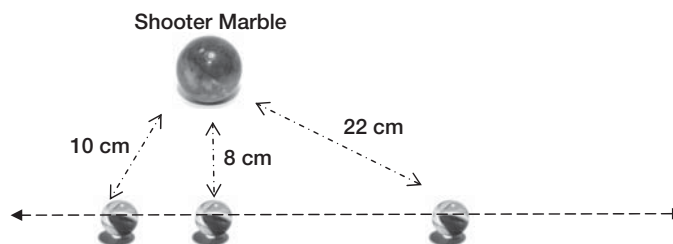

2. Explain how you located the positions of each additional marble. Label the distances between the marbles in the first row and in the second row.

3. Describe the relationship between the first and second rows of marbles.

4. Use a ruler to compare the length of the line segments connecting each original marble to the line segments connecting each additional marble.

5. What can you conclude about dilating a line that does not pass through the center of a dilation?



6. Consider line P . How could you show a dilation of this line by a factor of 2 using P as the center of dilation? Explain your reasoning.

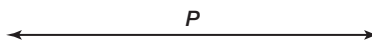

PROBLEM 2 Making a Shadow

You have volunteered to help at the children's booth at an art festival. The children that visit the booth will be able to create objects, like animals or people, out of poster board and craft sticks. Then, they will use a flashlight to create shadow puppets. Your job is to show the children how to use a flashlight and a wall to make their own puppet show.

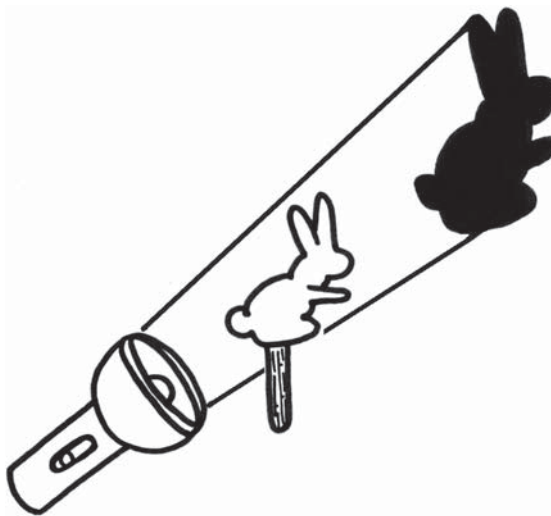

1. How does the size of the shadow puppet compare to the size of the object made out of poster board and craft sticks?

2. How does the shape of the shadow puppet compare to the shape of the object made out of poster board and craft sticks?

6



3. Do you think that the shadow is a transformation of the object? Why or why not?



Consider $\triangle ABC$, $\triangle DEF$, and point Y . Imagine that point Y is the flashlight and $\triangle DEF$ is the shadow of $\triangle ABC$.

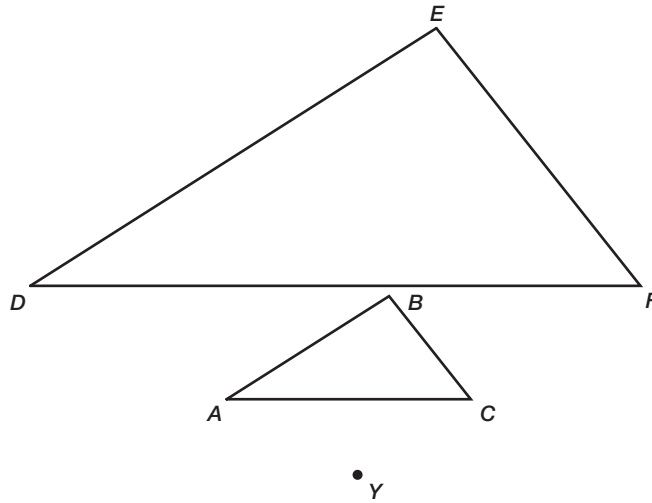

4. Draw the line segments \overline{YD} , \overline{YE} , \overline{YF} on the figure shown. These line segments show the path of the light from the flashlight.
Describe what these line segments connect.

5. Use a metric ruler to determine the actual lengths of \overline{YA} , \overline{YB} , \overline{YC} , \overline{YD} , \overline{YE} , and \overline{YF} to the nearest tenth of a centimeter.

6. Express the ratios $\frac{YD}{YA}$, $\frac{YE}{YB}$, and $\frac{YF}{YC}$ as decimals.

7. What do you notice about the ratios?

Remember that a ratio is a comparison of two numbers that uses division. The ratio of two numbers a and b (b cannot be zero), can be written in three ways.

a to b

$a : b$

$\frac{a}{b}$



8. Use a protractor to measure the corresponding angles in the triangles. What can you conclude?



9. What is the relationship between the image and pre-image in a dilation?

The shadow created by the flashlight is a dilation.

10. In any dilation:

- how will the corresponding angles in the image and pre-image compare?
- how will the ratios of the lengths of the corresponding sides compare?



11. What is the center of the dilation shown in Question 4?



12. Rectangle $L'M'N'P'$ is a dilation of rectangle $LMNP$. The center of dilation is point Z .

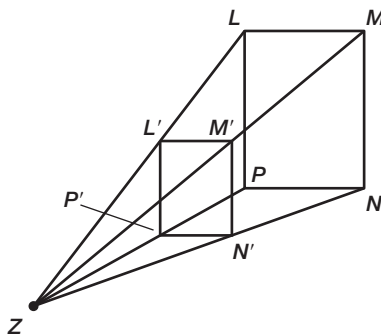

- a. Use a metric ruler to determine the actual lengths of \overline{ZL} , \overline{ZN} , \overline{ZM} , \overline{ZP} , $\overline{ZL'}$, $\overline{ZN'}$, $\overline{ZM'}$, and $\overline{ZP'}$ to the nearest tenth of a centimeter. Then express the ratios $\frac{ZL'}{ZL}$, $\frac{ZN'}{ZN}$, $\frac{ZM'}{ZM}$, and $\frac{ZP'}{ZP}$ as decimals.

- b. What do you notice about the ratios?

13. How does the image compare to the pre-image when:
- a. the scale factor is greater than 1?

- b. the scale factor is less than 1?

Recall that an image that is the result of a dilation is not always larger than the pre-image.



The ratios that you wrote in Questions 6 and 12 are the scale factors of each dilation.



6

PROBLEM 3 Larger or Smaller?



You can use your compass and a straightedge to perform a dilation. Consider $\triangle GHJ$ shown on the coordinate plane. You will dilate the triangle by using the origin as the center and by using a scale factor of 2.



1. How will the distance from the center of dilation to a point on the image of $\triangle G'H'J'$ compare to the distance from the center of dilation to a corresponding point on $\triangle GHJ$? Explain your reasoning.

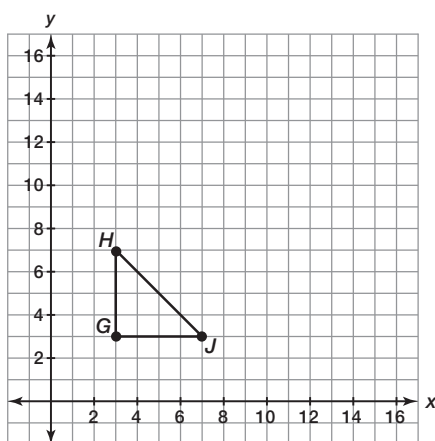

2. For each vertex of $\triangle GHJ$, draw a ray that starts at the origin and passes through the vertex.
3. Use the duplicate segment construction to locate the vertices of $\triangle G'H'J'$.
4. List the coordinates of the vertices of $\triangle GHJ$ and $\triangle G'H'J'$. How do the coordinates of the image compare to the coordinates of the pre-image?





5. Triangle $J'K'L'$ is a dilation of $\triangle JKL$. The center of dilation is the origin.

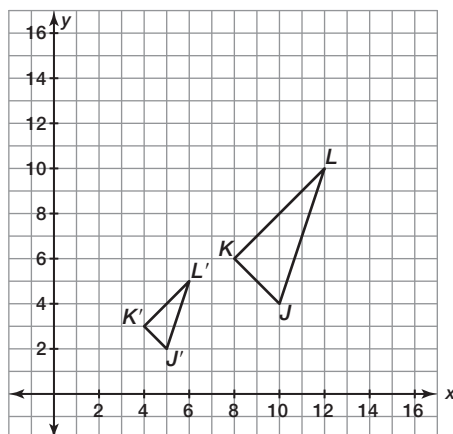

- a. List the coordinates of the vertices of $\triangle JKL$ and $\triangle J'K'L'$. How do the coordinates of the image compare to the coordinates of the pre-image?
- b. What is the scale factor of the dilation? Explain your reasoning.
- c. How do you think you can use the scale factor to determine the coordinates of the vertices of an image?



6. Use coordinate notation to describe the dilation of point (x, y) when the center of dilation is at the origin using a scale factor of k .

6

PROBLEM 4 Geometric Theorems and Similar Triangles

Similar triangles are triangles that have all pairs of corresponding angles congruent and all corresponding sides are proportional. Similar triangles have the same shape but not always the same size.



1. Triangle $HRY \sim$ Triangle JPT

Draw a diagram that illustrates this similarity statement and list all of the pairs of congruent angles and all of the proportional sides.

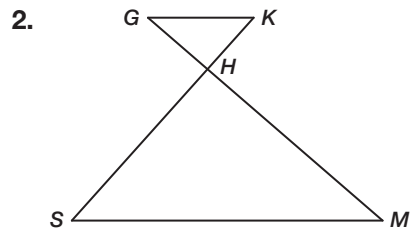

- a. What conditions are necessary to show triangle GHK is similar to triangle MHS ?

- b. Suppose $4GH = HM$.

Determine whether this given information is enough to prove that the two triangles are similar. Explain why you think they are similar or provide a counter-example if you think the triangles are not similar.

- c. Suppose \overline{GK} is parallel to \overline{MS} .

Determine whether this given information is enough to prove that the two triangles are similar. Explain why you think they are similar or provide a counter-example if you think the triangles are not similar.



- d. Suppose $\angle G \cong \angle S$.

Determine whether this given information is enough to prove that the two triangles are similar. Explain why you think they are similar or provide a counter-example if you think the triangles are not similar.

c. Suppose $(KH)(GH) = (SH)(MH)$

Describe a sequence of transformations that maps one triangle to the other triangle.



Be prepared to share your solutions and methods.

Similar Triangles or Not?

Similar Triangle Theorems

LEARNING GOALS

In this lesson, you will:

- Use constructions to explore similar triangle theorems.
- Explore the Angle-Angle (AA) Similarity Theorem.
- Explore the Side-Side-Side (SSS) Similarity Theorem.
- Explore the Side-Angle-Side (SAS) Similarity Theorem.

KEY TERMS

- Angle-Angle Similarity Theorem
- Side-Side-Side Similarity Theorem
- included angle
- included side
- Side-Angle-Side Similarity Theorem

An art projector is a piece of equipment that artists have used to create exact copies of artwork, to enlarge artwork, or to reduce artwork. A basic art projector uses a light bulb and a lens within a box. The light rays from the art being copied are collected onto a lens at a single point. The lens then projects the image of the art onto a screen as shown.

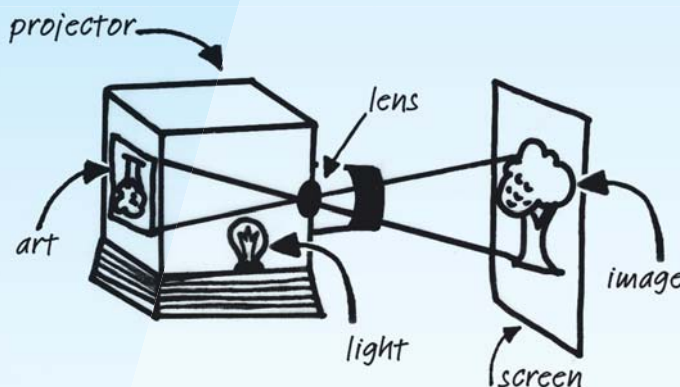

If the projector is set up properly, the triangles shown will be similar polygons. You can show that these triangles are similar without measuring all of the side lengths and all of the interior angles.

PROBLEM 1 Using Two Angles



In the previous lesson, you used transformations to prove that triangles are similar when their corresponding angles are congruent and their corresponding sides are proportional. In this problem, you will explore the similarity of two triangles using construction tools.

1. Identify all of the corresponding congruent angles and all of the corresponding proportional sides using the similar triangles shown.

$$\triangle RST \sim \triangle WXY$$

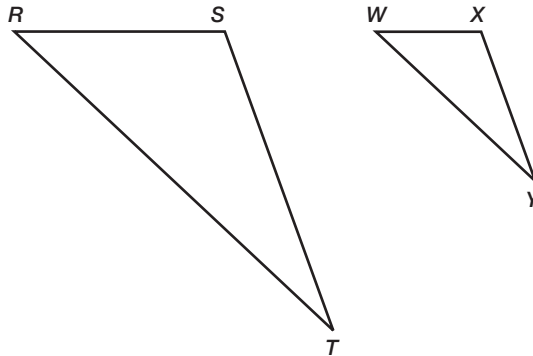

You can conclude that two triangles are similar if you are able to prove that all of their corresponding angles are congruent and all of their corresponding sides are proportional.

Let's use constructions to see if you can use fewer pairs of angles or fewer pairs of sides to show that triangles are similar.

2. Construct triangle $D'E'F'$ using only $\angle D$ and $\angle E$ in triangle DEF as shown. Make all the corresponding side lengths of triangle $D'E'F'$ different from the side lengths of triangle DEF .

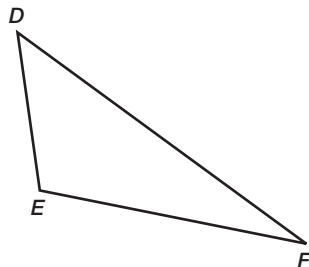



3. Measure the angles and sides of triangle $D'E'F'$ and triangle DEF . Are the two triangles similar? Explain your reasoning.

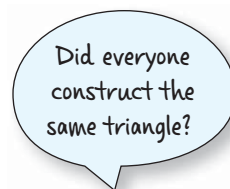

4. In triangles DEF and $D'E'F'$, two pairs of corresponding angles are congruent. Determine if this is sufficient information to conclude that the triangles are similar.



The **Angle-Angle Similarity Theorem** states: “If two angles of one triangle are congruent to two angles of another triangle, then the triangles are similar.”

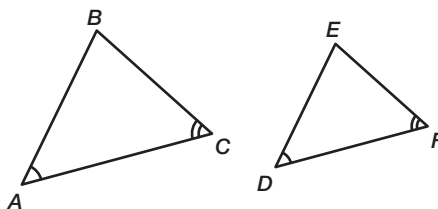

If $m\angle A = m\angle D$ and $m\angle C = m\angle F$, then $\triangle ABC \sim \triangle DEF$.

5. Explain why this similarity theorem is Angle-Angle instead of Angle-Angle-Angle.



6. The triangles shown are isosceles triangles. Do you have enough information to show that the triangles are similar? Explain your reasoning.

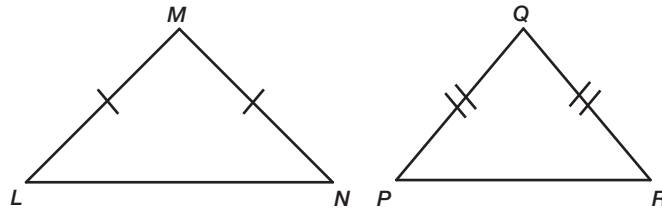

7. The triangles shown are isosceles triangles. Do you have enough information to show that the triangles are similar? Explain your reasoning.

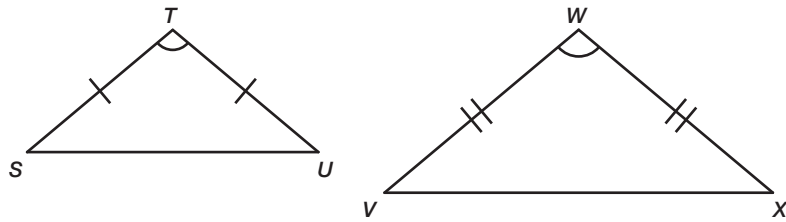

PROBLEM 2 Using Two and Three Proportional Sides



1. Construct triangle $D'E'F'$ by doubling the lengths of sides \overline{DE} and \overline{EF} . Construct the new $D'E'$ and $E'F'$ separately and then construct the triangle. This will ensure a ratio of 2:1. Do not duplicate angles.

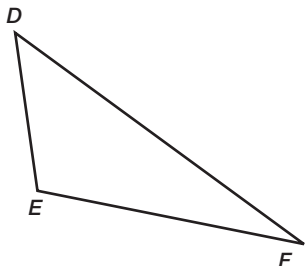

2. Measure the angles and sides of triangle $D'E'F'$ and triangle DEF . Are the two triangles similar? Explain your reasoning.

Did everyone construct the same triangle?



3. Two pairs of corresponding sides are proportional. Determine if this is sufficient information to conclude that the triangles are similar.

Not having sufficient information doesn't mean that the triangles are NOT similar. It just means that you can't know for sure whether the triangles are or are not similar.



6

4. Construct triangle $D'E'F'$ by doubling the lengths of sides \overline{DE} , \overline{EF} , and \overline{FD} . Construct the new side lengths separately, and then construct the triangle. Do not duplicate angles.

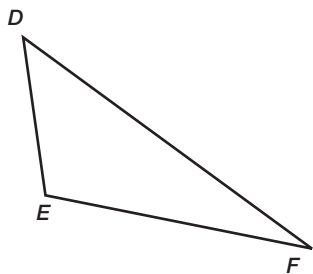

5. Measure the angles and sides of triangle $D'E'F'$ and triangle DEF . Are the two triangles similar? Explain your reasoning.



6



6. Three pairs of corresponding sides are proportional. Determine if this is sufficient information to conclude that the triangles are similar.



The **Side-Side-Side Similarity Theorem** states: “If all three corresponding sides of two triangles are proportional, then the triangles are similar.”

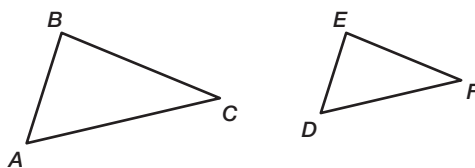

If $\frac{AB}{DE} = \frac{BC}{EF} = \frac{AC}{DF}$, then $\triangle ABC \sim \triangle DEF$.



Stacy says that the Side-Side-Side Similarity Theorem tells us that two triangles can have proportional sides, but not congruent angles, and still be similar. Michael doesn't think that's right, but he can't explain why.

7. Is Stacy correct? If not, explain why not.

8. Determine whether $\triangle UVW$ is similar to $\triangle XYZ$. If so, use symbols to write a similarity statement.

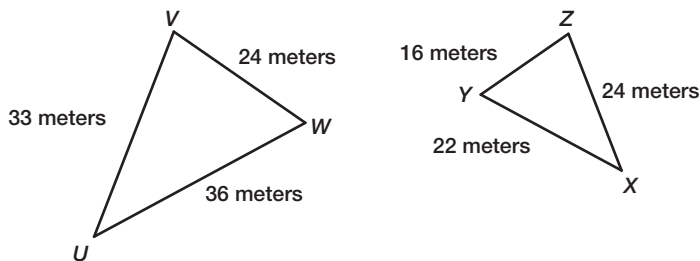

9. Describe how transformations could be used to determine whether two triangles are similar when all pairs of corresponding sides are proportional.

PROBLEM 3 Using Two Proportional Sides and an Angle



An **included angle** is an angle formed by two consecutive sides of a figure.
An **included side** is a line segment between two consecutive angles of a figure.

1. Construct triangle $D'E'F'$ by duplicating an angle and doubling the length of the two sides that make up that angle. Construct the new side lengths separately, and then construct the triangle.

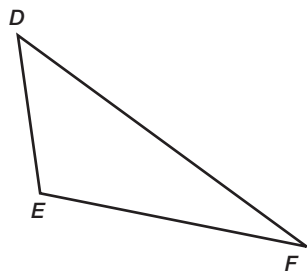

2. Measure the angles and sides of triangle $D'E'F'$ and triangle DEF . Are the two triangles similar? Explain your reasoning.

- Two pairs of corresponding sides are proportional and the corresponding included angles are congruent. Determine if this is sufficient information to conclude that the triangles are similar.
- Describe how transformations could be used to determine whether two triangles are similar when two pairs of corresponding sides are proportional and the included angles are congruent.

The **Side-Angle-Side Similarity Theorem** states: “If two of the corresponding sides of two triangles are proportional and the included angles are congruent, then the triangles are similar.”

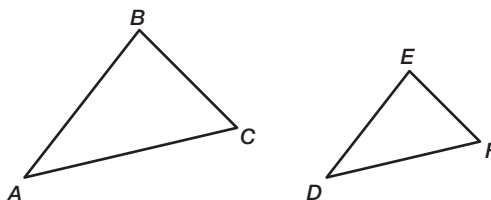

If $\frac{AB}{DE} = \frac{AC}{DF}$ and $\angle A \cong \angle D$, then $\triangle ABC \sim \triangle DEF$.

Talk the Talk



1. Gaelin is thinking of a triangle and he wants everyone in his class to draw a similar triangle. Complete the graphic organizer to describe the sides and angles of triangles he could provide.



Be prepared to share your solutions and methods.

Angle-Angle (AA)

Side-Angle-Side (SAS)

Similar Triangles

Side-Side-Side (SSS)

**Combinations of Sides and Angles
that Do Not Ensure Similarity**

Keep It in Proportion

Theorems About Proportionality

LEARNING GOALS

In this lesson, you will:

- Prove the Angle Bisector/Proportional Side Theorem.
- Prove the Triangle Proportionality Theorem.
- Prove the Converse of the Triangle Proportionality Theorem.
- Prove the Proportional Segments Theorem associated with parallel lines.
- Prove the Triangle Midsegment Theorem.

KEY TERMS

- Angle Bisector/Proportional Side Theorem
- Triangle Proportionality Theorem
- Converse of the Triangle Proportionality Theorem
- Proportional Segments Theorem
- Triangle Midsegment Theorem

Although geometry is a mathematical study, it has a history that is very much tied up with ancient and modern religions. Certain geometric ratios have been used to create religious buildings, and the application of these ratios in construction even extends back into ancient times.

Music, as well, involves work with ratios and proportions.

PROBLEM 1 Proving the Angle Bisector/Proportional Side Theorem



When an interior angle of a triangle is bisected, you can observe proportional relationships among the sides of the triangles formed. You will be able to prove that these relationships apply to all triangles.

The **Angle Bisector/Proportional Side Theorem** states: “A bisector of an angle in a triangle divides the opposite side into two segments whose lengths are in the same ratio as the lengths of the sides adjacent to the angle.”

To prove the Angle Bisector/Proportional Side Theorem, consider the statements and figure shown.

Given: \overline{AD} bisects $\angle BAC$

Prove: $\frac{AB}{AC} = \frac{BD}{CD}$

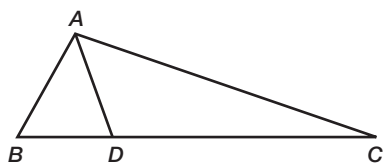

1. Draw a line parallel to \overline{AB} through point C. Extend \overline{AD} until it intersects the line. Label the point of intersection, point E.

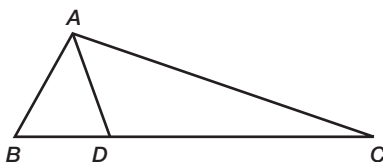



2. Complete the proof of the Angle Bisector/Proportional Side Theorem.

Statements	Reasons
1.	1. Given
2.	2. Construction
3.	3. Definition of angle bisector
4. $\angle BAE \cong \angle CEA$	4.
5.	5. Transitive Property of \cong
6.	6. If two angles of a triangle are congruent, then the sides opposite the angles are congruent.
7.	7. Definition of congruent segments
8.	8. Alternate Interior Angle Theorem
9. $\triangle DAB \sim \triangle DEC$	9.
10. $\frac{AB}{EC} = \frac{BD}{CD}$	10.
11.	11. Rewrite as an equivalent proportion
12. $\frac{AB}{BD} = \frac{AC}{CD}$	12.



PROBLEM 2 Applying the Angle Bisector/Proportional Side Theorem



1. On the map shown, North Craig Street bisects the angle formed between Bellefield Avenue and Ellsworth Avenue.

- The distance from the ATM to the Coffee Shop is 300 feet.
- The distance from the Coffee Shop to the Library is 500 feet.
- The distance from your apartment to the Library is 1200 feet.

Determine the distance from your apartment to the ATM.

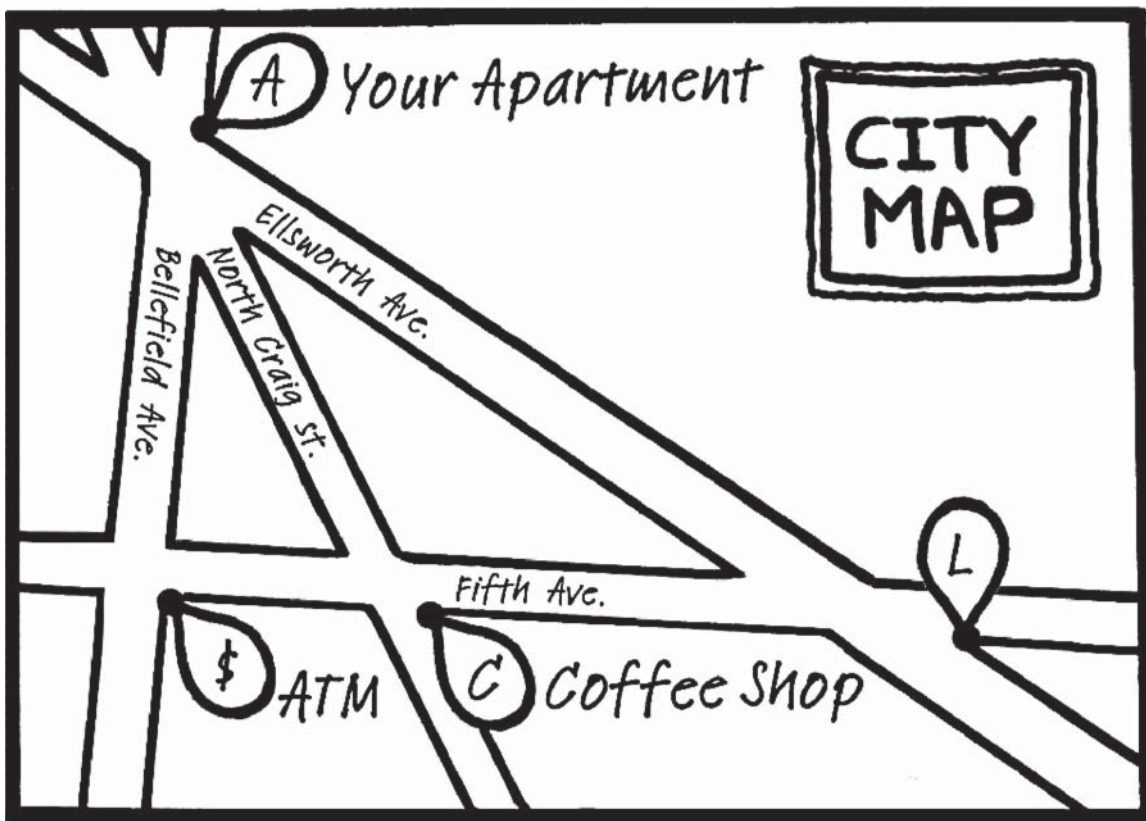

2. \overline{CD} bisects $\angle C$. Solve for DB .

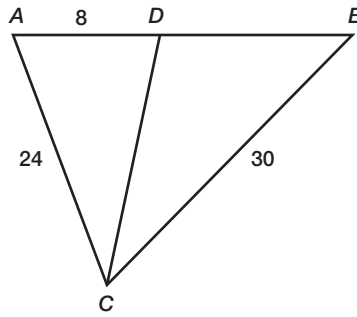

3. \overline{CD} bisects $\angle C$. Solve for AC .

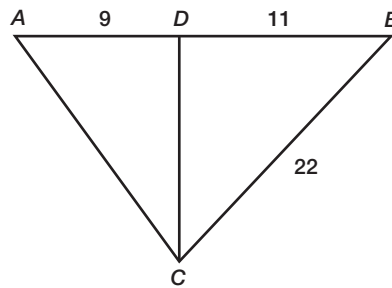

4. \overline{AD} bisects $\angle A$. $AC + AB = 36$. Solve for AC and AB .

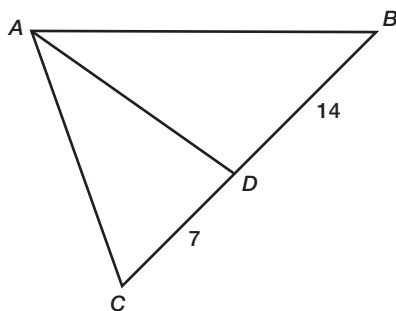

5. \overline{BD} bisects $\angle B$. Solve for AC .

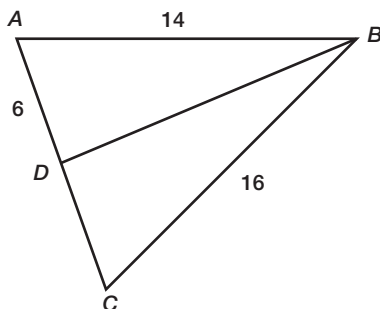

PROBLEM 3 Triangle Proportionality Theorem

The **Triangle Proportionality Theorem** states: “If a line parallel to one side of a triangle intersects the other two sides, then it divides the two sides proportionally.”

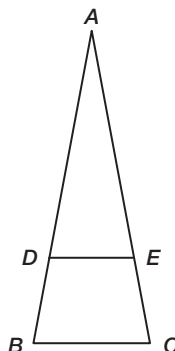

Given: $\overline{BC} \parallel \overline{DE}$

Prove: $\frac{BD}{DA} = \frac{CE}{EA}$



1. Write a paragraph proof to prove triangle ADE is similar to triangle ABC .

2. Cut out each statement and reason on the next page. Match them together, and then rearrange them in an appropriate order by numbering them to create a proof for the Triangle Proportionality Theorem.

Triangle ADE is similar to triangle ABC

Corresponding sides of similar triangles are proportional

$$\frac{BD}{DA} = \frac{CE}{EA}$$

Corresponding Angle Postulate

$$\angle AED \cong \angle C$$

Given

$$\overline{BC} \parallel \overline{DE}$$

Corresponding Angle Postulate

$$\frac{BA}{DA} = \frac{CA}{EA}$$

AA Similarity Theorem

$$BA = BD + DA \text{ and } CA = CE + EA$$

Substitution

$$\frac{BD + DA}{DA} = \frac{CE + EA}{EA}$$

Segment Addition Postulate

$$\angle ADE \cong \angle B$$

Simplify

Statements

Reasons



PROBLEM 4 Converse of the Triangle Proportionality Theorem



The **Converse of the Triangle Proportionality Theorem** states: “If a line divides two sides of a triangle proportionally, then it is parallel to the third side.”

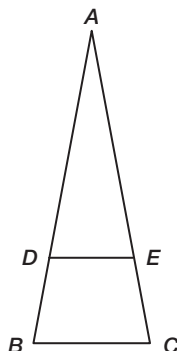

Given: $\frac{BD}{DA} = \frac{CE}{EA}$

Prove: $\overline{BC} \parallel \overline{DE}$

Prove the Converse of the Triangle Proportionality Theorem.



PROBLEM 5 Proportional Segments Theorem



The **Proportional Segments Theorem** states: “If three parallel lines intersect two transversals, then they divide the transversals proportionally.”

Given: $L_1 \parallel L_2 \parallel L_3$

Prove: $\frac{AB}{BC} = \frac{DE}{EF}$

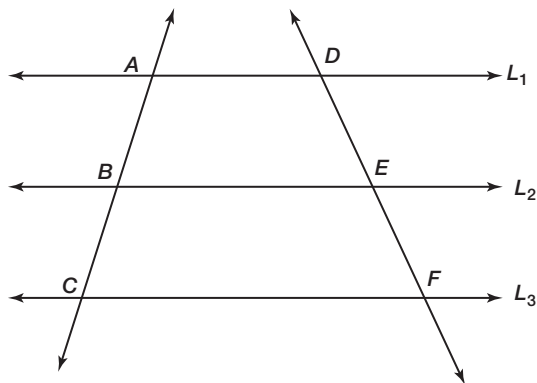

1. Through any two points there is exactly one line. Draw line segment CD to form triangle ACD and triangle FDC .

2. Let H be the point at which L_2 intersects line segment CD . Label point H .

3. Using the Triangle Proportionality Theorem and triangle ACD , what can you conclude?

4. Using the Triangle Proportionality Theorem and triangle FDC , what can you conclude?



5. What property of equality will justify the prove statement?

6

PROBLEM 6 Triangle Midsegment Theorem



The **Triangle Midsegment Theorem** states: “The midsegment of a triangle is parallel to the third side of the triangle and is half the measure of the third side of the triangle.”



1. Use the diagram to write the “Given” and “Prove” statements for the Triangle Midsegment Theorem.

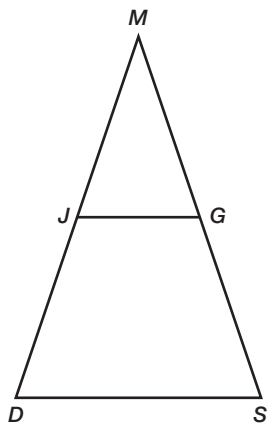

Given:

Prove:

2. Prove the Triangle Midsegment Theorem.





3. Ms. Zoid asked her students to determine whether \overline{RD} is a midsegment of $\triangle TUY$, given $TY = 14$ cm and $RD = 7$ cm.

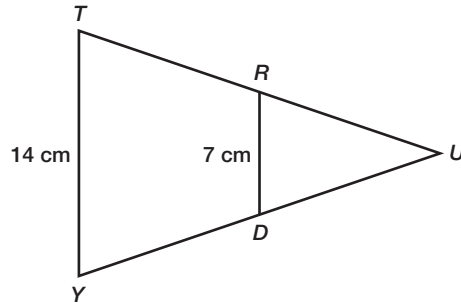

Carson told Alicia that using the Triangle Midsegment Theorem, he could conclude that \overline{RD} is a midsegment. Is Carson correct? How should Alicia respond if Carson is incorrect?

4. Ms. Zoid drew a second diagram on the board and asked her students to determine if \overline{RD} is a midsegment of triangle TUY , given $\overline{RD} \parallel \overline{TY}$.

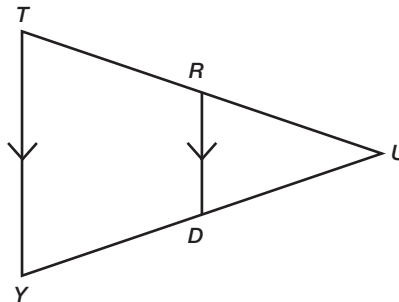

Alicia told Carson that using the Triangle Midsegment Theorem, she could conclude that \overline{RD} is a midsegment. Is Alicia correct? How should Carson respond if Alicia is incorrect?





In $\triangle BJG$, the midpoint of \overline{BJ} is $F(-3, 5)$. The midpoint of \overline{BG} is $A(-6, -5)$.
The midpoint of \overline{GJ} is $R(6, -5)$.

- Use the Triangle Midsegment Theorem to determine the coordinates of the vertices of $\triangle BJG$. Show all of your work.

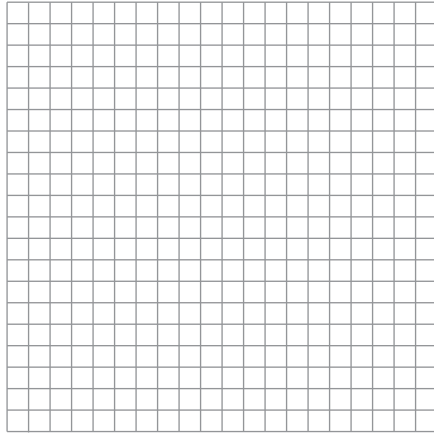

6. Determine the perimeter of $\triangle BJK$ and the perimeter of $\triangle FAR$.
Round each radical to the nearest tenth. Show all of your work.



Be prepared to share your solutions and methods.

Geometric Mean

More Similar Triangles

LEARNING GOALS

In this lesson, you will:

- Explore the relationships created when an altitude is drawn to the hypotenuse of a right triangle.
- Prove the Right Triangle/Altitude Similarity Theorem.
- Use the geometric mean to solve for unknown lengths.

KEY TERMS

- Right Triangle/Altitude Similarity Theorem
- geometric mean
- Right Triangle Altitude/Hypotenuse Theorem
- Right Triangle Altitude/Leg Theorem

People have been building bridges for centuries so that they could cross rivers, valleys, or other obstacles. The earliest bridges probably consisted of a log that connected one side to the other—not exactly the safest bridge!

The longest bridge in the world is the Danyang-Kunshan Grand Bridge in China. Spanning 540,700 feet, it connects Shanghai to Nanjing. Construction was completed in 2010 and employed 10,000 people, took 4 years to build, and cost approximately \$8.5 billion.

Lake Pontchartrain Causeway is the longest bridge in the United States. Measuring *only* 126,122 feet, that's less than a quarter of the Danyang-Kunshan Grand Bridge. However, it currently holds the record for the longest bridge over continuous water. Not too shabby!

PROBLEM 1 Right Triangles



A bridge is needed to cross over a canyon. The dotted line segment connecting points S and R represents the bridge. The distance from point P to point S is 45 yards. The distance from point Q to point S is 130 feet. How long is the bridge?

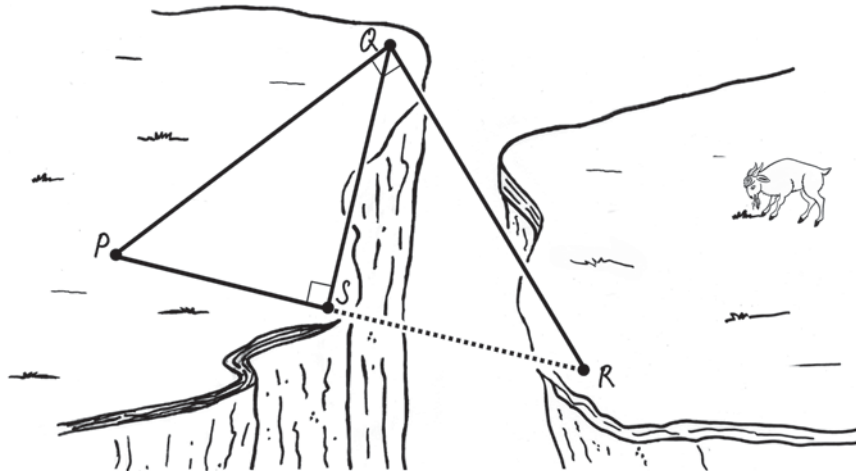

To determine the length of the bridge, you must first explore what happens when an altitude is drawn to the hypotenuse of a right triangle.

When an altitude is drawn to the hypotenuse of a right triangle, it forms two smaller triangles. All three triangles have a special relationship.

1. Construct an altitude to the hypotenuse in the right triangle ABC . Label the altitude CD .

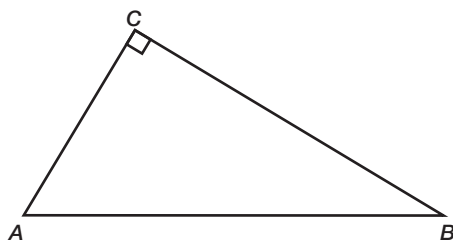

We're going to explore these relationships in several triangles first. Then we can answer the question at the beginning of this problem.





2. Name all right triangles in the figure.

3. Trace each of the triangles on separate pieces of paper and label all the vertices on each triangle. Cut out each triangle. Label the vertex of each triangle. Arrange the triangles so that all of the triangles have the same orientation. The hypotenuse, the shortest leg, and the longest leg should all be in corresponding positions. You may have to flip triangles over to do this.

4. Name each pair of triangles that are similar. Explain how you know that each pair of triangles are similar.

5. Write the corresponding sides of each pair of triangles as proportions.

6



The **Right Triangle/Altitude Similarity Theorem** states: “If an altitude is drawn to the hypotenuse of a right triangle, then the two triangles formed are similar to the original triangle and to each other.”

PROBLEM 2 Geometric Mean



When an altitude of a right triangle is constructed from the right angle to the hypotenuse, three similar right triangles are created. This altitude is a *geometric mean*.

The **geometric mean** of two positive numbers a and b is the positive number x such that $\frac{a}{x} = \frac{x}{b}$.

Two theorems are associated with the altitude to the hypotenuse of a right triangle.

The **Right Triangle Altitude/Hypotenuse Theorem** states: “The measure of the altitude drawn from the vertex of the right angle of a right triangle to its hypotenuse is the geometric mean between the measures of the two segments of the hypotenuse.”

The **Right Triangle Altitude/Leg Theorem** states: “If the altitude is drawn to the hypotenuse of a right triangle, each leg of the right triangle is the geometric mean of the hypotenuse and the segment of the hypotenuse adjacent to the leg.”

1. Use the diagram from Problem 1 to answer each question.

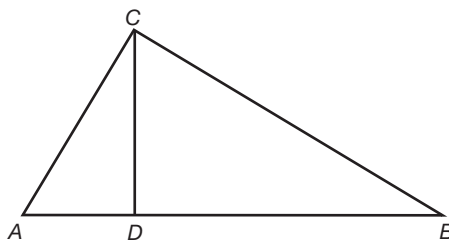

- a. Write a proportion to demonstrate the Right Triangle Altitude/Hypotenuse Theorem?

- b. Write a proportion to demonstrate the Right Triangle Altitude/Leg Theorem?



2. In each triangle, solve for x .

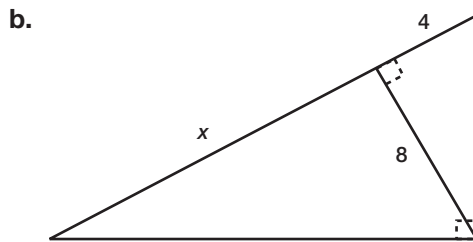
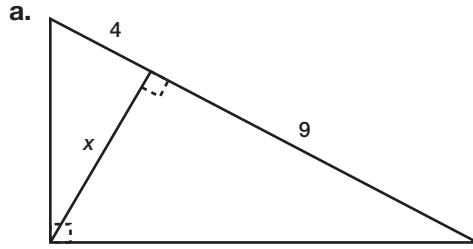

c.

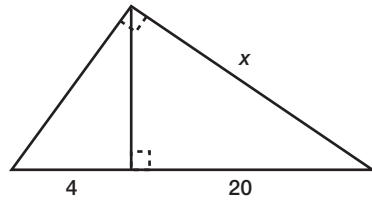

d.

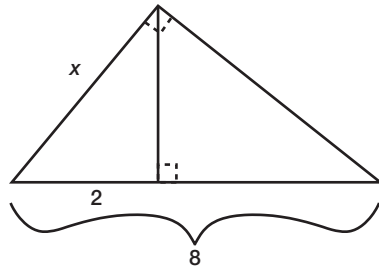



3. In the triangle shown, solve for x , y , and z .

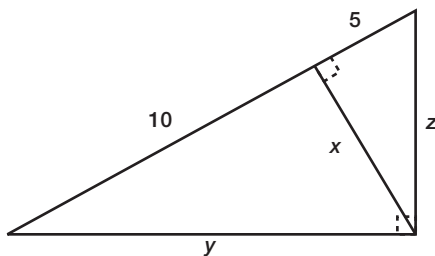

PROBLEM 3 Bridge Over the Canyon



1. Solve for the length of the bridge in Problem 1 using the geometric mean.



Be prepared to share your solutions and methods.

Proving the Pythagorean Theorem

6.5

Proving the Pythagorean Theorem and the Converse of the Pythagorean Theorem

LEARNING GOALS

In this lesson, you will:

- Prove the Pythagorean Theorem using similar triangles.
- Prove the Converse of the Pythagorean Theorem using algebraic reasoning.

The Pythagorean Theorem is one of the most famous theorems in mathematics.

And the proofs of the theorem are just as famous. It may be the theorem with the most different proofs. The book *Pythagorean Proposition* alone contains 370 proofs.

The scarecrow in the film *The Wizard of Oz* even tries to recite the Pythagorean Theorem upon receiving his brain. He proudly states, “The sum of the square roots of any two sides of an isosceles triangle is equal to the square root of the remaining side. Oh, joy! Oh, rapture! I’ve got a brain!”

Sadly the scarecrow’s version of the theorem is wrong—so much for that brain the wizard gave him!

PROBLEM 1 Proving the Pythagorean Theorem with Similar Triangles

Use the Right Triangle/Altitude Similarity Theorem to prove the Pythagorean Theorem.

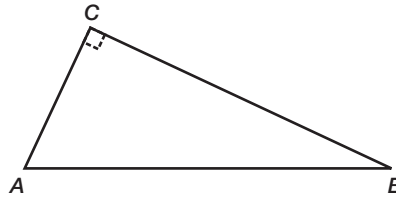

Given: Triangle ABC with right angle C

Prove: $AC^2 + CB^2 = AB^2$



1. Construct altitude CD to hypotenuse AB .
2. Applying the Right Triangle/Altitude Similarity Theorem, what can you conclude?
3. Write a proportional statement describing the relationship between the longest leg and hypotenuse of triangle ABC and triangle CBD .
4. Rewrite the proportional statement you wrote in Question 3 as a product.
5. Write a proportional statement describing the relationship between the shortest leg and hypotenuse of triangle ABC and triangle ACD .

6. Rewrite the proportional statement you wrote in Question 5 as a product.
7. Add the statement in Question 4 to the statement in Question 6.
8. Factor the statement in Question 7.
9. What is equivalent to $DB + AD$?
-  10. Substitute the answer to Question 9 into the answer to Question 8 to prove the Pythagorean Theorem.

PROBLEM 2 Proving the Pythagorean Theorem with Algebraic Reasoning

Use the diagram shown and the following questions to prove the Pythagorean Theorem.

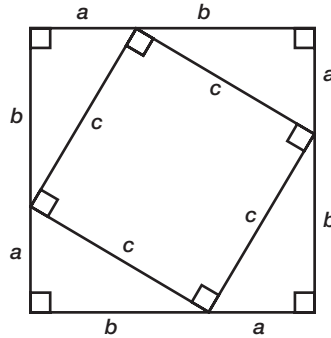

1. What is the area of the larger square?

2. What is the total area of the four right triangles?

3. What is the area of the smaller square?



4. What is the relationship between the area of the four right triangles, the area of the smaller square, and the area of the larger square?

PROBLEM 3 Proving the Converse of the Pythagorean Theorem

Use the diagram shown and the following questions to prove the Converse of the Pythagorean Theorem.

A large square is composed with four identical right triangles in its corners.

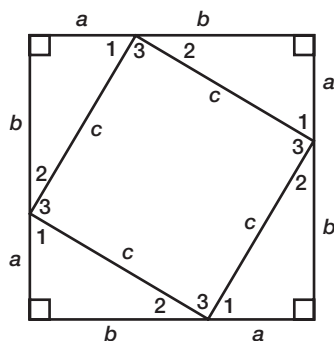

Recall, the Converse of the Pythagorean Theorem states: "If $a^2 + b^2 = c^2$, then a and b are the lengths of the legs of a right triangle and c is the length of the hypotenuse."



1. What can you conclude about $m\angle 1 + m\angle 2 + m\angle 3$?
2. Use the Triangle Sum Theorem to determine $m\angle 1 + m\angle 2$.
3. Knowing $m\angle 1 + m\angle 2$, what can you conclude about $m\angle 3$?
4. What does $m\angle 3$ tell you about the quadrilateral inside of the large square?
5. What is the area of one of the right triangles?

6. What is the area of the quadrilateral inside the large square?

7. Write an expression that represents the combined areas of the four right triangles and the quadrilateral inside the large square. Use your answers from Question 16, parts (e) and (f).

8. Write an expression to represent the area of the large square, given that one side is expressed as $(a + b)$. Simplify your answer.

9. Write an equation using the two different expressions representing the area of the large square from Questions 7 and 8. Then, solve the equation to prove the Converse of the Pythagorean Theorem.



Be prepared to share your solutions and methods.

Indirect Measurement

Application of Similar Triangles

LEARNING GOALS

In this lesson, you will:

- Identify similar triangles to calculate indirect measurements.
- Use proportions to solve for unknown measurements.

KEY TERM

- indirect measurement

You would think that determining the tallest building in the world would be pretty straightforward. Well, you would be wrong.

There is actually an organization called the Council on Tall Buildings and Urban Habitat that officially certifies buildings as the world's tallest. It was founded at Lehigh University in 1969 with a mission to study and report "on all aspects of the planning, design, and construction of tall buildings."

So, what does it take to qualify for world's tallest? The Council only recognizes a building if at least 50% of its height is made up of floor plates containing habitable floor area. Any structure that does not meet this criteria is considered a tower. These buildings might have to settle for being the world's tallest tower instead!

PROBLEM 1 How Tall Is That Flagpole?

At times, measuring something directly is impossible, or physically undesirable. When these situations arise, **indirect measurement**, the technique that uses proportions to calculate measurement, can be implemented. Your knowledge of similar triangles can be very helpful in these situations.



Use the following steps to measure the height of the school flagpole or any other tall object outside. You will need a partner, a tape measure, a marker, and a flat mirror.

Step 1: Use a marker to create a dot near the center of the mirror.

Step 2: Face the object you would like to measure and place the mirror between yourself and the object. You, the object, and the mirror should be collinear.

Step 3: Focus your eyes on the dot on the mirror and walk backward until you can see the top of the object on the dot, as shown.

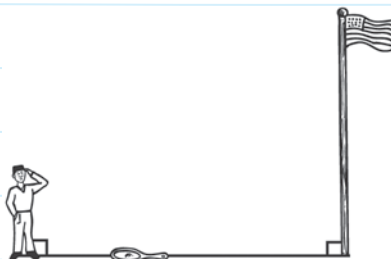

Step 4: Ask your partner to sketch a picture of you, the mirror, and the object.

Step 5: Review the sketch with your partner. Decide where to place right angles, and where to locate the sides of the two triangles.

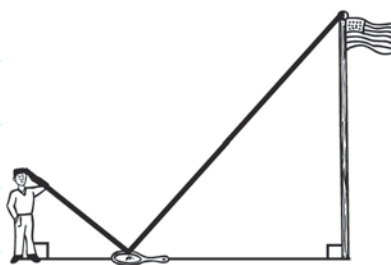

Step 6: Determine which segments in your sketch can easily be measured using the tape measure. Describe their locations and record the measurements on your sketch.

1. How can similar triangles be used to calculate the height of the object?
2. Use your sketch to write a proportion to calculate the height of the object and solve the proportion.
3. Compare your answer with others measuring the same object. How do the answers compare?
4. What are some possible sources of error that could result when using this method?
5. Switch places with your partner and identify a second object to measure. Repeat this method of indirect measurement to solve for the height of the new object.



PROBLEM 2 How Tall Is That Oak Tree?



1. You go to the park and use the mirror method to gather enough information to calculate the height of one of the trees. The figure shows your measurements. Calculate the height of the tree.

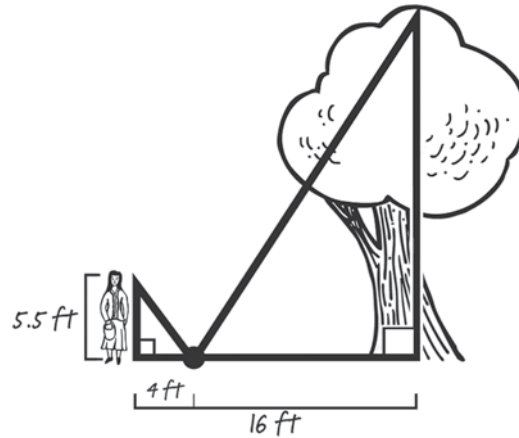

2. Stacey wants to try the mirror method to measure the height of one of her trees. She calculates that the distance between her and the mirror is 3 feet and the distance between the mirror and the tree is 18 feet. Stacey's eye height is 60 inches. Draw a diagram of this situation. Then, calculate the height of this tree.

Remember, whenever you are solving a problem that involves measurements like length (or weight), you may have to rewrite units so they are the same.





3. Stacey notices that another tree casts a shadow and suggests that you could also use shadows to calculate the height of the tree. She lines herself up with the tree's shadow so that the tip of her shadow and the tip of the tree's shadow meet. She then asks you to measure the distance from the tip of the shadows to her, and then measure the distance from her to the tree. Finally, you draw a diagram of this situation as shown below. Calculate the height of the tree. Explain your reasoning.

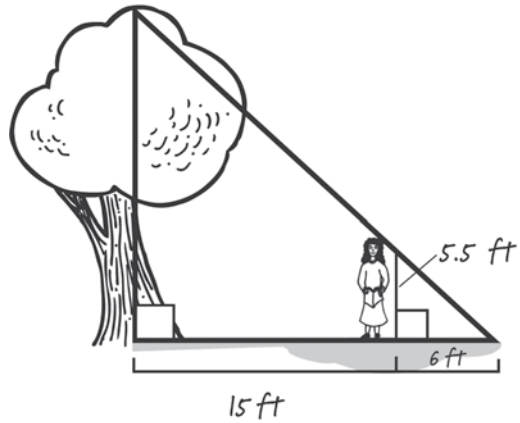

PROBLEM 3 How Wide Is That Creek?

1. You stand on one side of the creek and your friend stands directly across the creek from you on the other side as shown in the figure.

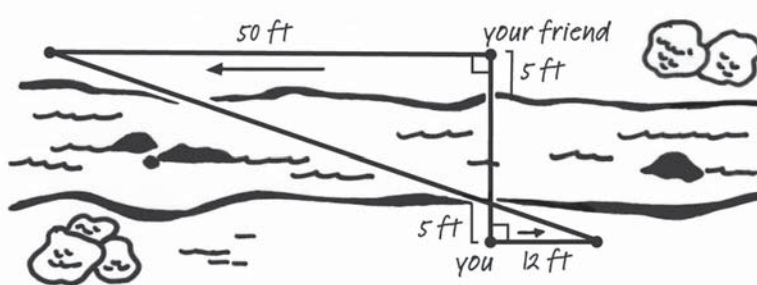

It is not reasonable for you to directly measure the width of a creek, but you can use indirect measurement to measure the width.



Your friend is standing 5 feet from the creek and you are standing 5 feet from the creek. You and your friend walk away from each other in opposite parallel directions. Your friend walks 50 feet and you walk 12 feet.

- a. Label any angle measures and any angle relationships that you know on the diagram. Explain how you know these angle measures.
- b. How do you know that the triangles formed by the lines are similar?

- c. Calculate the distance from your friend's starting point to your side of the creek. Round your answer to the nearest tenth, if necessary.



- d. What is the width of the creek? Explain your reasoning.



2. There is also a ravine (a deep hollow in the earth) on another edge of the park. You and your friend take measurements like those in Problem 3 to indirectly calculate the width of the ravine. The figure shows your measurements. Calculate the width of the ravine.

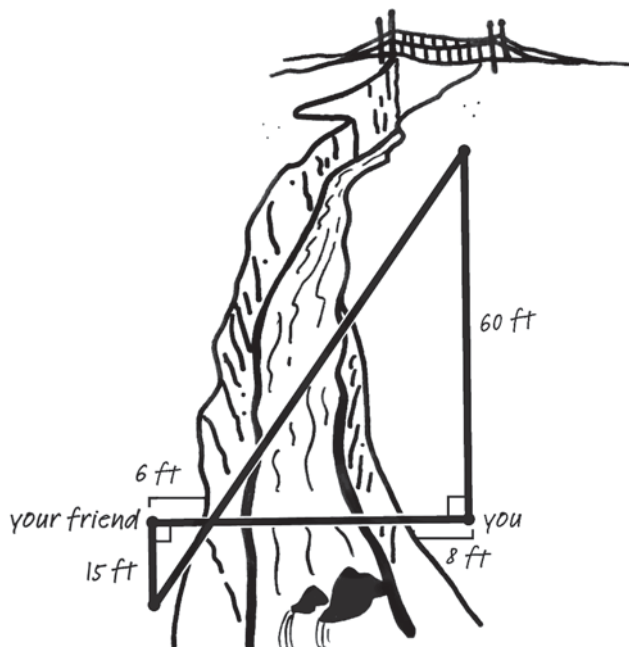

3. There is a large pond in the park. A diagram of the pond is shown below. You want to calculate the distance across the widest part of the pond, labeled as \overline{DE} . To indirectly calculate this distance, you first place a stake at point A . You chose point A so that you can see the edge of the pond on both sides at points D and E , where you also place stakes. Then, you tie a string from point A to point D and from point A to point E . At a narrow portion of the pond, you place stakes at points B and C along the string so that \overline{BC} is parallel to \overline{DE} . The measurements you make are shown on the diagram. Calculate the distance across the widest part of the pond.

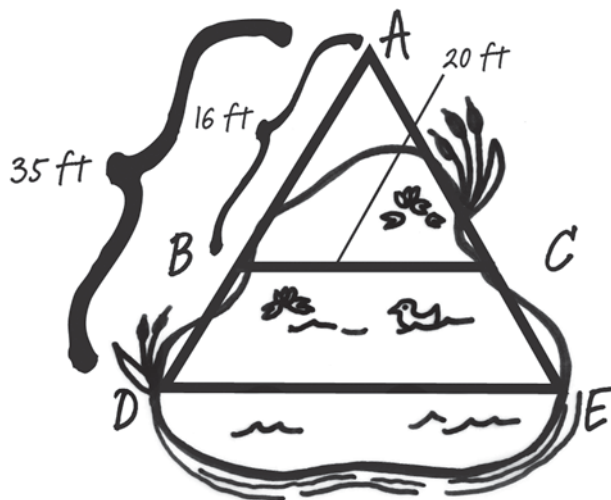

Be prepared to share your solutions and methods.

Chapter 6 Summary

KEY TERMS

- similar triangles (6.1)
- included angle (6.2)
- included side (6.2)
- geometric mean (6.4)
- indirect measurement (6.6)

POSTULATES AND THEOREMS

- Angle-Angle Similarity Theorem (6.2)
- Side-Side-Side Similarity Theorem (6.2)
- Triangle Proportionality Theorem (6.3)
- Converse of the Triangle Proportionality Theorem (6.3)
- Proportional Segments Theorem (6.3)
- Triangle Midsegment Theorem (6.3)
- Side-Angle-Side Similarity Theorem (6.2)
- Angle Bisector/Proportional Side Theorem (6.3)
- Right Triangle/Altitude Similarity Theorem (6.4)
- Right Triangle Altitude/Hypotenuse Theorem (6.4)
- Right Triangle Altitude/Leg Theorem (6.4)

6.1

Comparing the Pre-image and Image of a Dilation

A dilation increases or decreases the size of a figure. The original figure is the pre-image, and the dilated figure is the image. A pre-image and an image are similar figures, which means they have the same shape but different sizes.

A dilation can be described by drawing line segments from the center of dilation through each vertex on the pre-image and the corresponding vertex on the image. The ratio of the length of the segment to a vertex on the pre-image and the corresponding vertex on the image is the scale factor of the dilation. A scale factor greater than 1 produces an image that is larger than the pre-image. A scale factor less than 1 produces an image that is smaller than the pre-image.

Example

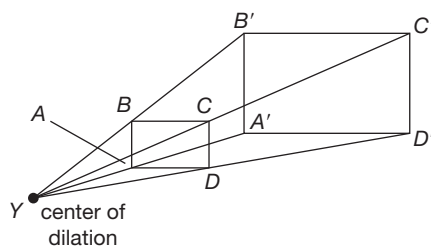

$YD = 3.5$	$YD' = 7.7$
$YB = 2.5$	$YB' = ?$
$YC = ?$	$YC' = 3.3$
$YA = 1.0$	$YA' = ?$

scale factor = $\frac{YD'}{YD}$	$\frac{YB'}{YB} = 2.2$	$\frac{YC'}{YC} = 2.2$	$\frac{YA'}{YA} = 2.2$
$= \frac{7.7}{3.5}$	$YB' = 2.2\overline{YB}$	$YC' = 2.2YC$	$YA' = 2.2YA$
$= 2.2$	$YB' = 2.2(2.5)$	$\frac{YC'}{2.2} = YC$	$YA' = 2.2(1.0)$
	$YB' = 5.5$	$\frac{3.3}{2.2} = YC$	$YA' = 2.2$
		$1.5 = \overline{YC}$	

6.1

Dilating a Triangle on a Coordinate Grid

The length of each side of an image is the length of the corresponding side of the pre-image multiplied by the scale factor. On a coordinate plane, the coordinates of the vertices of an image can be found by multiplying the coordinates of the vertices of the pre-image by the scale factor. If the center of dilation is at the origin, a point (x, y) is dilated to (kx, ky) by a scale factor of k .

Example

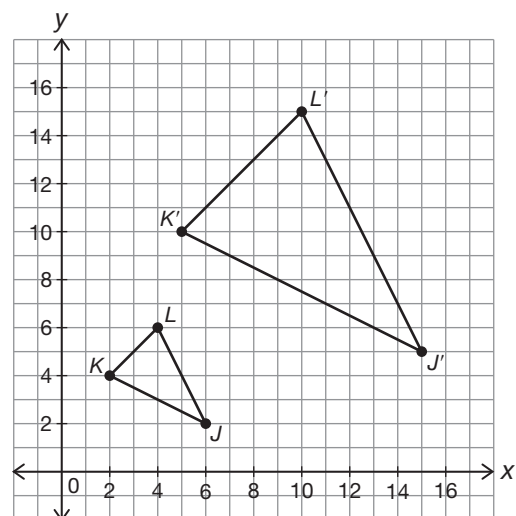

The center of dilation is the origin.

The scale factor is 2.5.

$$J(6, 2) \longrightarrow J'(15, 5)$$

$$K(2, 4) \longrightarrow K'(5, 10)$$

$$L(4, 6) \longrightarrow L'(10, 15)$$

6.1

Using Geometric Theorems to Prove that Triangles are Similar

All pairs of corresponding angles and all corresponding sides of similar triangles are congruent. Geometric theorems can be used to prove that triangles are similar. The Alternate Interior Angle Theorem, the Vertical Angle Theorem, and the Triangle Sum Theorem are examples of theorems that might be used to prove similarity.

Example

By the Alternate Interior Angle Theorem, $\angle A \cong \angle D$ and $\angle B \cong \angle E$. By the Vertical Angle Theorem, $\angle ACB \cong \angle ECD$. Since the triangles have three pairs of corresponding angles that are congruent, the triangles have the same shape and $\triangle ABC \cong \triangle DEC$.

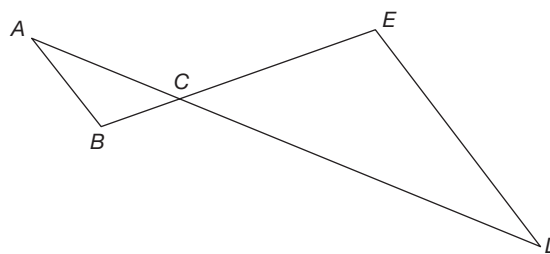

6.1 Using Transformations to Prove that Triangles are Similar

Triangles can also be proven similar using a sequence of transformations. The transformations might include rotating, dilating, and reflecting.

Example

Given: $\overline{AC} \parallel \overline{FD}$

Translate $\triangle ABC$ so that \overline{AC} aligns with \overline{FD} .
Rotate $\triangle ABC$ 180° about the point C so that \overline{AC} again aligns with \overline{FD} . Translate $\triangle ABC$ until point C is at point F . If we dilate $\triangle ABC$ about point C to take point B to point E , then \overline{AB} will be mapped onto \overline{ED} , and \overline{BC} will be mapped onto \overline{EF} . Therefore, $\triangle ABC$ is similar to $\triangle DEF$.

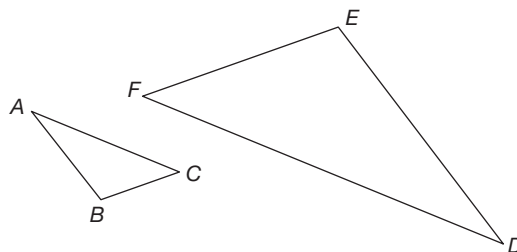

6.2 Using Triangle Similarity Theorems

Two triangles are similar if they have two congruent angles, if all of their corresponding sides are proportional, or if two of their corresponding sides are proportional and the included angles are congruent. An included angle is an angle formed by two consecutive sides of a figure. The following theorems can be used to prove that triangles are similar:

- The Angle-Angle (AA) Similarity Theorem—If two angles of one triangle are congruent to two angles of another triangle, then the triangles are similar.
- The Side-Side-Side (SSS) Similarity Theorem—If the corresponding sides of two triangles are proportional, then the triangles are similar.
- The Side-Angle-Side (SAS) Similarity Theorem—If two of the corresponding sides of two triangles are proportional and the included angles are congruent, then the triangles are similar.

Example

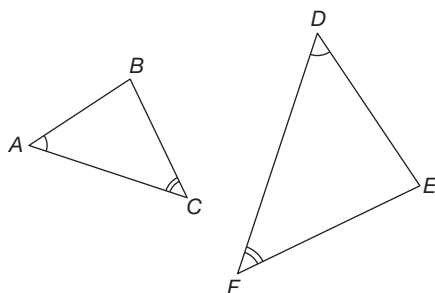

Given: $\angle A \cong \angle D$

$\angle C \cong \angle F$

Therefore, $\triangle ABC \sim \triangle DEF$ by the AA Similarity Theorem.

6.3

Applying the Angle Bisector/Proportional Side Theorem

When an interior angle of a triangle is bisected, you can observe proportional relationships among the sides of the triangles formed. You can apply the Angle Bisector/Proportional Side Theorem to calculate side lengths of bisected triangles.

- Angle Bisector/Proportional Side Theorem—A bisector of an angle in a triangle divides the opposite side into two segments whose lengths are in the same ratio as the lengths of the sides adjacent to the angle.

Example

The map of an amusement park shows locations of the various rides.

Given:

- Path E bisects the angle formed by Path A and Path B.
- Path A is 143 feet long.
- Path C is 65 feet long.
- Path D is 55 feet long.

Let x equal the length of Path B.

$$\frac{x}{55} = \frac{143}{65} \quad \text{Path B is 121 feet long.}$$

$$x = 121$$

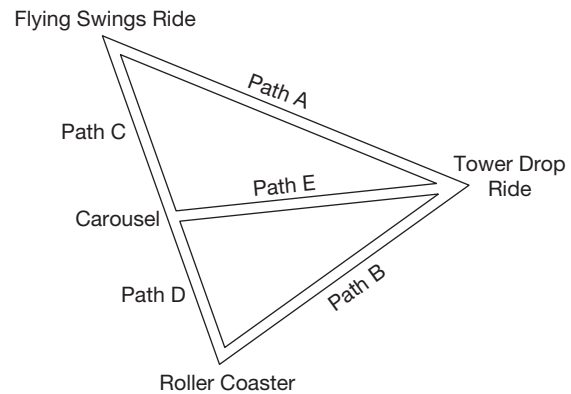

6.3

Applying the Triangle Proportionality Theorem

The Triangle Proportionality Theorem is another theorem you can apply to calculate side lengths of triangles.

- Triangle Proportionality Theorem—If a line parallel to one side of a triangle intersects the other two sides, then it divides the two sides proportionally.

Example

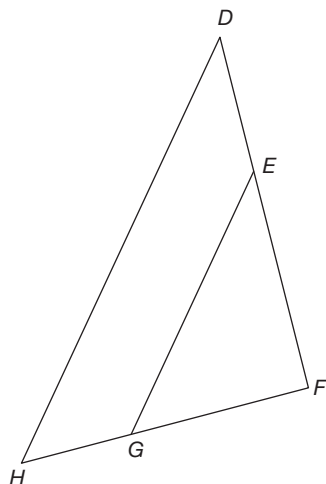

Given: $DH \parallel EG$

$$DE = 30$$

$$EF = 45$$

$$GH = 25$$

$$FG = ?$$

$$\frac{DE}{EF} = \frac{GH}{FG}$$

$$FG = \frac{GH \cdot EF}{DE}$$

$$= \frac{(25)(45)}{30}$$

$$= 37.5$$

6.3 Applying the Converse of the Triangle Proportionality Theorem

The Converse of the Triangle Proportionality Theorem allows you to test whether two line segments are parallel.

- Converse of the Triangle Proportionality Theorem—If a line divides two sides of a triangle proportionally, then it is parallel to the third side.

Example

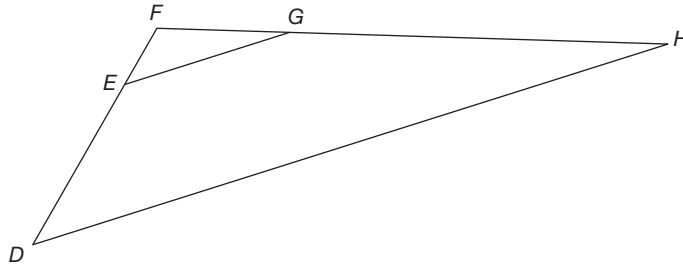

$$\begin{aligned} \text{Given: } DE &= 33 & \frac{DE}{EF} &= \frac{GH}{FG} \\ EF &= 11 & \frac{33}{11} &= \frac{66}{22} \\ GH &= 22 & 3 &= 3 \\ FG &= 66 \\ \text{Is } \overline{DH} &\parallel \overline{EG}? \end{aligned}$$

Applying the Converse of the Triangle Proportionality, we can conclude that $\overline{DH} \parallel \overline{EG}$.

6.3 Applying the Proportional Segments Theorem

The Proportional Segments Theorem provides a way to calculate distances along three parallel lines, even though they may not be related to triangles.

- Proportional Segments Theorem—If three parallel lines intersect two transversals, then they divide the transversals proportionally.

Example

Given: $L_1 \parallel L_2 \parallel L_3$

$$AB = 52$$

$$BC = 26$$

$$DE = 40$$

$$EF = ?$$

$$\frac{AB}{BC} = \frac{DE}{EF}$$

$$AB \cdot EF = DE \cdot BC$$

$$EF = \frac{DE \cdot BC}{AB}$$

$$= \frac{(40)(26)}{52}$$

$$= 20$$

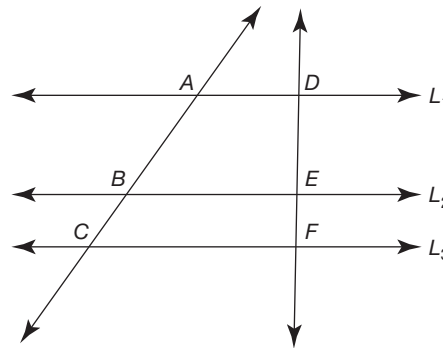

6.3

Applying the Triangle Midsegment Theorem

The Triangle Midsegment Theorem relates the lengths of the sides of a triangle when a segment is drawn parallel to one side.

- Triangle Midsegment Theorem—The midsegment of a triangle is parallel to the third side of the triangle and half the measure of the third side of the triangle.

Example

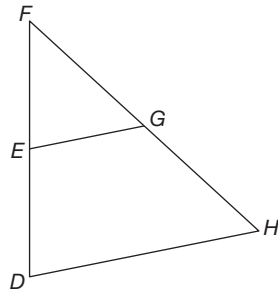

$$\begin{aligned} \text{Given: } DE &= 9 & EF &= 9 \\ FG &= 11 & GH &= 11 \\ DH &= 17 \end{aligned}$$

Since $DE = EF$ and $FG = GH$, point E is the midpoint of \overline{DF} , and G is the midpoint of \overline{FH} . \overline{EG} is the midsegment of $\triangle DFH$.

$$EG = \frac{1}{2}DH = \frac{1}{2}(17) = 8.5$$

6.4

Using the Geometric Mean and Right Triangle/Altitude Theorems

Similar triangles can be formed by drawing an altitude to the hypotenuse of a right triangle.

- Right Triangle/Altitude Similarity Theorem—If an altitude is drawn to the hypotenuse of a right triangle, then the two triangles formed are similar to the original triangle and to each other.

The altitude is the geometric mean of the triangle's bases. The geometric mean of two positive numbers a and b is the positive number x such as $\frac{a}{x} = \frac{x}{b}$. Two theorems are associated with the altitude to the hypotenuse as a geometric mean.

- The Right Triangle Altitude/Hypotenuse Theorem—The measure of the altitude drawn from the vertex of the right angle of a right triangle to its hypotenuse is the geometric mean between the measures of the two segments of the hypotenuse.
- The Right Triangle Altitude/Leg Theorem—If the altitude is drawn to the hypotenuse of a right triangle, each leg of the right triangle is the geometric mean of the hypotenuse and the segment of the hypotenuse adjacent to the leg.

Example

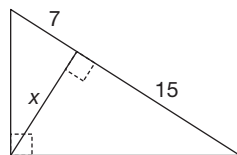

$$\begin{aligned} \frac{7}{x} &= \frac{x}{15} \\ x^2 &= 105 \\ x &= \sqrt{105} \approx 10.2 \end{aligned}$$

6.5

Proving the Pythagorean Theorem Using Similar Triangles

The Pythagorean Theorem relates the squares of the sides of a right triangle: $a^2 + b^2 = c^2$, where a and b are the bases of the triangle and c is the hypotenuse. The Right Triangle/Altitude Similarity Theorem can be used to prove the Pythagorean Theorem.

Example

Given: Triangle ABC with right angle C .

- Construct altitude CD to hypotenuse AB , as shown.
- According to the Right Triangle/Altitude Similarity Theorem, $\triangle ABC \sim \triangle CAD$.
- Since the triangles are similar, $\frac{AB}{CB} = \frac{CB}{DB}$ and $\frac{AB}{AC} = \frac{AC}{AD}$.
- Solve for the squares: $CB^2 = AB \times DB$ and $AC^2 = AB \times AD$.
- Add the squares: $CB^2 + AC^2 = AB \times DB + AB \times AD$
- Factor: $CB^2 + AC^2 = AB(DB + AD)$
- Substitute: $CB^2 + AC^2 = AB(AB) = AB^2$

This proves the Pythagorean Theorem: $CB^2 + AC^2 = AB^2$

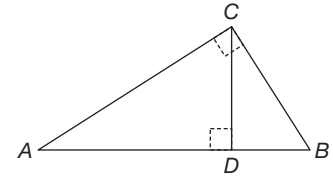

6.5

Proving the Pythagorean Theorem Using Algebraic Reasoning

Algebraic reasoning can also be used to prove the Pythagorean Theorem.

Example

- Write and expand the area of the larger square:
 $(a + b)^2 = a^2 + 2ab + b^2$
- Write the total area of the four right triangles:
 $4 \left(\frac{1}{2} ab \right) = 2ab$
- Write the area of the smaller square:
 c^2
- Write and simplify an equation relating the area of the larger square to the sum of the areas of the four right triangles and the area of the smaller square:

$$a^2 + 2ab + b^2 = 2ab + c^2$$

$$a^2 + b^2 = c^2$$

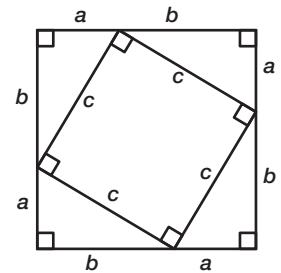

6.5

Proving the Converse of the Pythagorean Theorem

Algebraic reasoning can also be used to prove the Converse of the Pythagorean Theorem: "If $a^2 + b^2 = c^2$, then a and b are the lengths of the legs of a right triangle and c is the length of the hypotenuse."

Example

Given: Triangle ABC with right angle C .

- Relate angles 1, 2, 3: $m\angle 1 + m\angle 2 + m\angle 3 = 180^\circ$
- Use the Triangle Sum Theorem to determine $m\angle 1 + m\angle 2$.

$$m\angle 1 + m\angle 2 = 90^\circ$$

- Determine $m\angle 3$ from the small right angles:

$$\text{Since } m\angle 1 + m\angle 2 = 90^\circ, m\angle 3 \text{ must also equal } 90^\circ.$$

- Identify the shape of the quadrilateral inside the large square: Since the quadrilateral has four congruent sides and four right angles, it must be a square.
- Determine the area of each right triangle: $A = \frac{1}{2}ab$
- Determine the area of the center square: c^2
- Write the sum of the areas of the four right triangles and the center square: $4\left(\frac{1}{2}ab\right) + c^2$
- Write and expand an expression for the area of the larger square: $(a + b)^2 = a^2 + 2ab + b^2$
- Write and simplify an equation relating the area of the larger square to the sum of the areas of the four right triangles and the area of the smaller square:

$$a^2 + 2ab + b^2 = 2ab + c^2$$

$$a^2 + b^2 = c^2$$

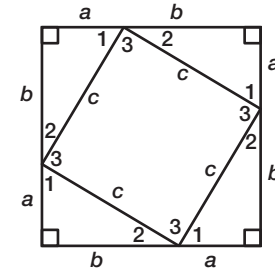

6.6

Use Similar Triangles to Calculate Indirect Measurements

Indirect measurement is a method of using proportions to calculate measurements that are difficult or impossible to make directly. A knowledge of similar triangles can be useful in these types of problems.

Example

Let x be the height of the tall tree.

$$\frac{x}{20} = \frac{32}{18}$$

$$x = \frac{(32)(20)}{18}$$

$$x \approx 35.6$$

The tall tree is about 35.6 feet tall.

